



# CONVEYOR COMPONENTS COMPANY

Division of Material Control, Inc.

130 Seltzer Road, PO Box 167 • Croswell, MI 48422 USA

PHONE: (810) 679-4211 • TOLL FREE (800) 233-3233 • FAX: (810) 679-4510

Email: [info@conveyorcomponents.com](mailto:info@conveyorcomponents.com) • <http://www.conveyorcomponents.com>

## MODEL MSD MOTION CONTROL INSTALLATION AND OPERATION

The Model MSD is a combination of a motion-sensing unit and a tachometer controller. There is rugged sensor enclosed in a heavy-duty cast aluminum housing, and control electronics are contained in a separate unit away from dirt, vibration, and temperature fluctuations.

The MSD-800 is a dual speed controller with two set points permitting it to indicate two under-speed points, two over-speed points, or one each under-speed and over-speed point. At the same time, the control unit displays the actual shaft RPM (or the rate of your choice) on the digital readout.

### Operation:

A precision metal disc with slots on its periphery is used in the sensor to generate electronic pulses as the disc rotates past an infra-red light source. These pulses are transmitted to the control unit where the signal is analyzed and the relays are activated or deactivated at preset signal speeds. The control unit is designed to permit two signal set points. Field adjustment of the signal set points is easily accomplished through the buttons on the face of the control unit.

### Technical Information:

#### **MSD-1 (or MSD-1X) Sensor:**

|                               |  |
|-------------------------------|--|
| Input:                        | 12 VDC from the control unit   |
| Output:                       | 12 VDC square wave to control unit   |
| Operating Temperature Range:  | -10°C to +55°C (14°F to +131°F)  |
| Minimum Normal Running Speed: | 1 RPM (MSD-800 Series controller will register 0 RPM between 0 RPM and approximately 0.6 RPM)  |
| Maximum Speed Limit:          | 1000 RPM   |
| Shaft Load:                   | 125 lbs. radial, 100 lbs. end thrust   |
| Rotation:                     | Clockwise or Counter-clockwise   |
| Drive Torque:                 | 1 inch-pound   |
| Shaft:                        | 5/8" dia. x 1 1/4" long stainless steel  |
| Enclosure:                    | 319 cast aluminum;<br>NEMA Type 3S, 4, 4X compliant (MSD-1);<br>Optional: Type 7: Class I (Div. 1 & 2) Groups C & D; and Type 9 Class II: (Div. 1 & 2) Groups F & G compliant (MSD-1X) |
| Bearings:                     | Permanently lubricated and sealed for life ball bearings   |
| Operating Range:              | 0-1000 RPM   |
| Signal Accuracy               | <u>Running Speed</u><br>50   |

#### **MSD-800 Control Unit:**

|                           |  |
|---------------------------|--|
| Power Input:              | 100 - 240 VAC, 50/60 Hz (MSD-800)<br>Optional: 24 VDC (MSD-800-24)   |
| Power Consumption:        | Less than 10 VA (AC input)<br>Less than 5 W (DC input)   |
| Output Power to Sensor:   | 12 VDC   |
| Signal Input From Sensor: | 12 VDC square-wave from sensor   |
| Output 1:                 | SPST Relay: rated 5 amps resistive at a maximum of 250 VAC;<br>Transistor: NPN open collector. When 100mA /30 VDC, residual voltage = 1.5 VDC max. |

Output 2: SPDT rated 5 amps resistive at 125/250 VAC;  
 Operating Temperature Range: 0°C to +50°C (32°F to +122°F)  
 Storage Temperature Range: -20°C to +65°C (-4°F to +149°F)  
 Reading Accuracy: ±.1 to ±1 RPM  
 Alarm Set Accuracy: ±.001 to ±1 RPM  
 Mounting: 1/16 DIN panel mount (45 mm × 45 mm cutout)  
 Certifications: UL, CE

**Installation and Wiring:**

Mount the MSD-1 sensor in any position on a smooth, flat surface using ¼” mounting bolts and lock washers. If vibration is extreme, dowel two mounting holes and use bolts in the others. The sensor shaft must be in line or parallel with the drive shaft.

For conduit installation, use only hubs of suitable sizes that are UL/CSA approved for WATERTIGHT use. Install per the hub manufacturer’s instructions. Be sure the location selected will provide adequate wire bending space.

Use two conductor shielded cable (such as our MSD-14 or Belden 8760 equivalent) to connect the MSD-800 control unit with the MSD-1 sensor; up to a maximum of 4000 ft [1220 m] of cable should be used.

The control unit should be mounted (or the wiring threaded through the mounting bracket and mounting slot) prior to final wiring. With the mounting bracket removed, slide the control unit into a 1/16 DIN (45 mm × 45 mm) cutout. Then slide the mounting bracket onto the rear of the unit and secure with the attached screws.

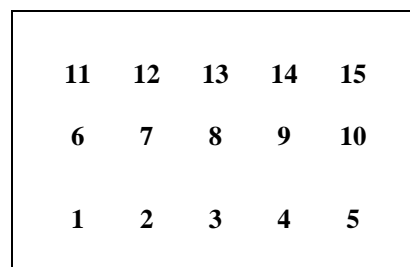
The control unit contains three failsafe output circuits: one SPST relay (Output 1, normally open), one Transistor (Output 1, NPN), and one SPDT relay (Output 2). Output relays/transistor are energized under normal conditions and de-energize under alarm conditions. The relays/transistor de-energize (alarm) in the event of power failure, during a start-up delay, and during a reset event. NOTE: Relay contacts are labeled in reference to their de-energized (alarm) state.

To connect an external reset, wire a normally-open circuit between terminal 11 (Sensor Power: Ground) and terminal 7 (Reset 1).

**Figure 1: Control unit Terminal Functions**

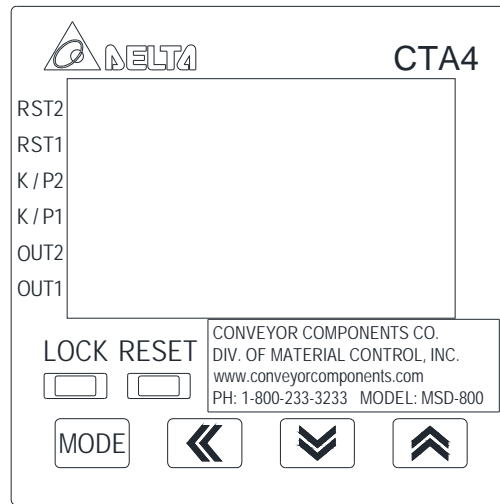
| Control Unit Terminal # | Function                                  |
|-------------------------|---|
| 1                       | Output 2: Normally Open                   |
| 2                       | Output 2: Normally Closed                 |
| 3                       | Output 2: Common                          |
| 4                       | Power: 100-240 VAC                        |
| 5                       | Power: 100-240 VAC                        |
| 6                       | Sensor Power: 12+ VDC (Sensor Terminal 2) |
| 7                       | Reset: initiates a reset event.           |
| 8                       | Not Used                                  |
| 9                       | Output 1 Transistor: Emitter              |
| 10                      | Output 1: Relay Common                    |
| 11                      | Sensor Power: Ground (Sensor Terminal 3)  |
| 12                      | Sensor Signal (Sensor Terminal 1)         |
| 13                      | Not Used                                  |
| 14                      | Output 1 Transistor: Collector            |
| 15                      | Output 1 Relay: Normally Open             |

**Figure 2: Control Unit Terminal Arrangement**



## Button Functions

**Figure 3: Controller Interface**



### **MODE:**

Single Press: Cycle between set points while in Tachometer View.  
Cycle between settings while in the Menu  
Exit a setting or set point edit.

Hold for 3s: Enter or leave the Menu

<< Begin a setting or set point edit and cycle cursor between digits

↑ and ↓: Edit a set point or setting.

### **LOCK:**

First Press: Unit enters Keypad Lock Mode 1: Disables all button functions except for the LOCK button. To unlock, simultaneously press MODE and <<.

Second Press: Unit enters Keypad Lock Mode 2: The Menu is disabled. Relay set points may be changed and RESET button functions. To unlock, simultaneously press MODE and <<.

**RESET:** Clears tachometer reading and resets relays when pressed. Re-initiates any set start-up delay when released

### Display:

Red Digits: Displays the present RPM while in tachometer view, and the function setting while the Menu  
Green Digits: Displays the value of set points while in tachometer view, and the setting value while in the Menu  
SET 1/2: Displays which set point/output is being displayed or edited  
OUT1: Lit when output 1 is energized  
OUT2: Lit when output 2 is energized  
K/P1: Lit when Keypad Lock Mode 1 is enabled  
K/P2: Lit when Keypad Lock Mode 2 is enabled  
RST1: Lit when a reset signal is read from the reset button on the unit  
RST2: Lit when an external reset signal is read

### Control Unit Menu:

The control unit comes fully programmed from the factory, ready for use with the MSD-1 sensor. The primary menu settings that may need to be changed in the field is the Tachometer Output Mode and the Startup Delay.

FUnC Primary Mode Function: This should be set to TACH.  
tAcotmd Tachometer Output Mode: Sets functions of set points for output relays.  
2Lo1Lo Output 1(SPST + transistor) = Overspeed detection; Output 2(SPDT) = Overspeed detection

|        |  |
|--------|--|
| 2Lo1Hi | Output 1(SPST + transistor) = Underspeed detection; Output 2(SPDT) = Overspeed detection   |
| 2Hi1Lo | Output 1(SPST + transistor) = Overspeed detection; Output 2(SPDT) = Underspeed detection   |
| 2Hi1Hi | Output 1(SPST + transistor) = Underspeed detection; Output 2(SPDT) = Underspeed detection  |
| C SPED | Counting Speed: the maximum reading speed from the sensor in counts per second. Can be set 1, 30, 200, 5K (5000) or 10K (10 000). This should be set the smallest value greater than $\frac{\text{max running speed (in RPM)}}{1.2}$ , but not more than 5000. The factory setting is 5K.  |
| Point  | Decimal point: Defines how many decimal digits are visible on the readout and the set points. Can be set to 0, 1, 2, or 3 (NOTE: This setting affects the decimal placement of the set points. If you change this setting you must reset your set points afterward).                       |
| PSCALE | Pre-Scale Value: This value scales the reading from Hz to the desired unit of measurement. To display the sensor shaft RPM the Pre-Scale Value should be 1.2. To display in units other than RPM, change the Pre-Scale Value to $1.2 \times [\text{Desired Units per Sensor Shaft RPM}]$ . |
| St tAC | Tachometer Startup Delay: Time delay from power up to tachometer operation in seconds (0 - 99.9).  |
| St AvG | Average Value Input Filter: Implements the averaging filter for more stable readings.  |
| 0      | No averaging   |
| 1      | Averages 2 latest data points  |
| 2      | Averages 4 latest data points  |
| 3      | Averages 8 latest data points  |
| rtSr   | Minimum Reset Signal Length: 20ms or 1ms.  |
| inPtLC | Input Signal Type: NPN or PNP available. NPN Required for use with MSD-1 Sensor  |

Menu Factory Defaults

| FUnC    | TACH            |
|---------|-----------------|
| tAcotmd | User Preference |
| C SPED  | 5K              |
| Point   | 0               |
| PSCALE  | 1.2             |
| St tAC  | 0               |
| St AvG  | 0               |
| rtSr    | 20ms            |
| inPtLC  | NPN             |

Factory Assistance:

If assistance is needed to locate difficulties with a unit or you would like information about alternate control devices, please call the factory at 1-800-233-3233 or via e-mail at [info@conveyorcomponents.com](mailto:info@conveyorcomponents.com).

To help solve a problem quickly, please have as much of the following information as possible when you make your call:

- Model Number
- Date Purchased
- Brief Application Information
- Brief Description of the Problem.

EQUIPMENT SHIPPED BACK TO THE FACTORY WITHOUT PROPER AUTHORIZATION WILL BE REFUSED AND RETURNED AT THE SHIPPER'S EXPENSE.

## Model MSD Troubleshooting Tips

### PROBLEM:

Display is blank.

### SOLUTION:

- a. Verify input power to controller.

### PROBLEM:

Display reads "0" rpm.

### SOLUTION:

- a. Verify the sensor cover is properly affixed. Sunlight or other bright light may interfere with the sensor readings if the enclosure is left open.
- b. Incorrect connections to sensor. Verify terminal 1 to 12, 2 to 6, 3 to 11. Verify terminal 3 to 11 is shield on both ends.
- c. Verify that the Input Signal Type is set NPN instead of PNP
- d. Verify a reset signal is not being read.
- e. Verify Startup Delay length. The controller will display 0 during the startup delay.

### PROBLEM:

Relays do not trip when set point is reached.

### SOLUTION:

- a. Verify the set value is correct.
- b. Verify that the appropriate relay is being used.
- c. Verify the Relay Output is properly set to HI or LO.
- d. Verify the relay wiring, the relays are labeled in their non-energized state.
- e. The relays are dry, unpowered relays. Verify that the COM is sourced with appropriate voltage.

### PROBLEM:

RPM display is erratic or inconsistent.

### SOLUTION:

- a. Verify the sensor cover is properly affixed. Sunlight or other bright light may interfere with the sensor readings if the enclosure is left open.
- b. Verify that the Counting Speed setting is greater than  $\frac{\text{max running speed (in RPM)}}{1.2}$
- c. Verify that Belden 8760 or similar shielded cable is being used between sensor and controller.
- d. Verify that less than 4000 ft. [1220 m] of cable is being used.
- e. Verify that the sensor cable is enclosed in a metal conduit without any power carrying cabling.
- f. Verify the controller is not mounted near any Variable Frequency Drives.
- g. Verify that controller FUNC is set to TACH

### PROBLEM:

RPM display does not match the actual conveyor speed.

### SOLUTION:

- a. For RPM verify that the Pre-Scale value is set to 1.2
- b. For other units change the Pre-scale value to  $1.2 \times [\text{Desired Units per RPM}]$

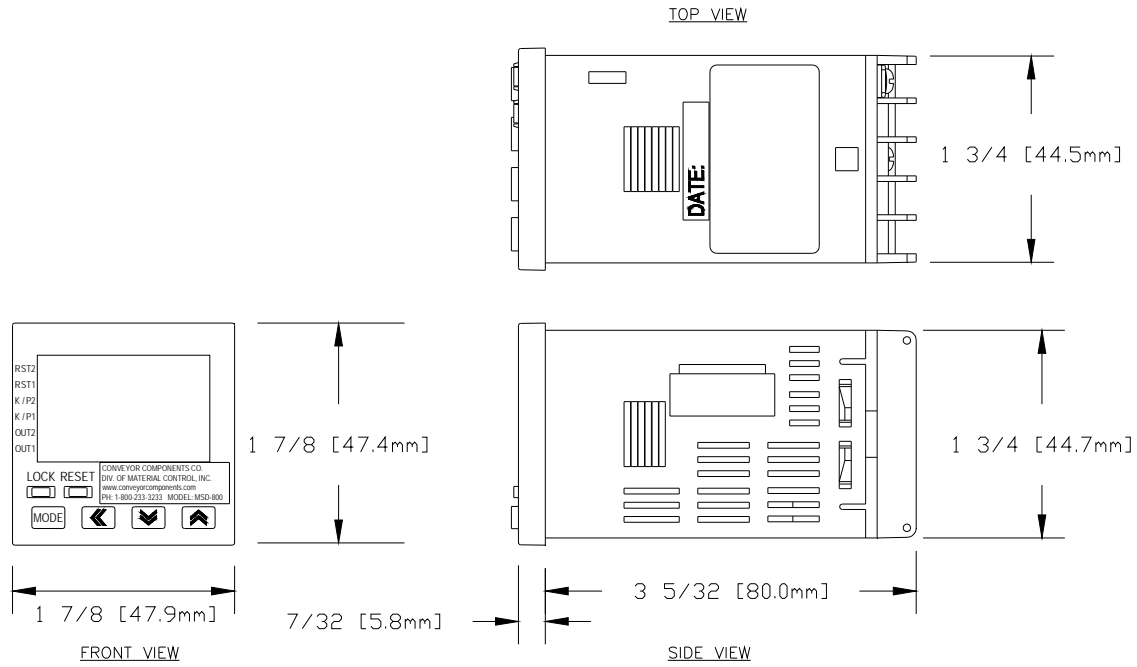
### PROBLEM:

Nothing happens when buttons are pressed. The controller settings can't be adjusted.

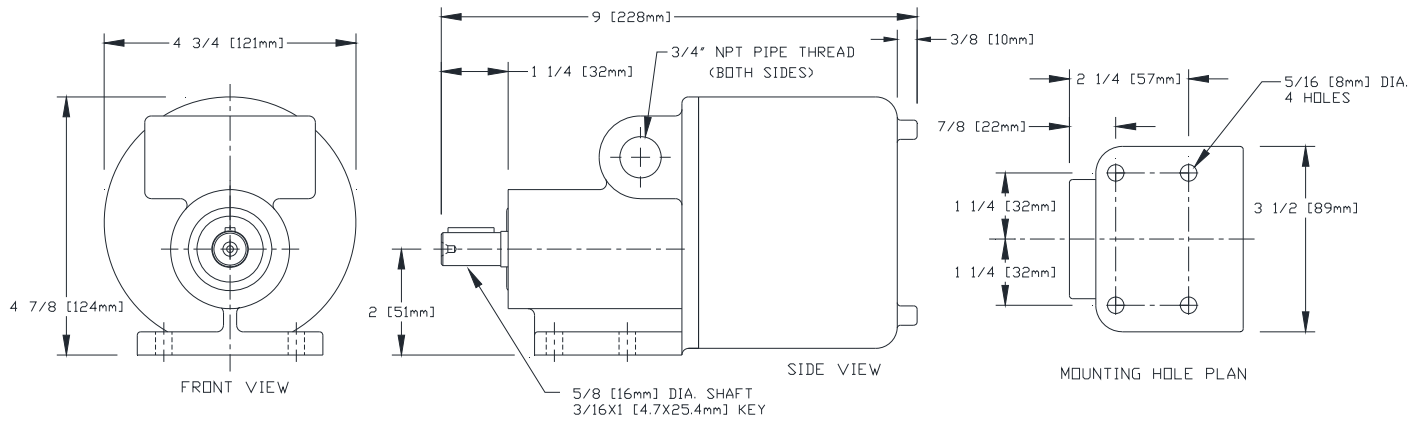
### SOLUTION:

- a. The control unit may be in lock mode. Press the MODE and << buttons at the same time to disable.

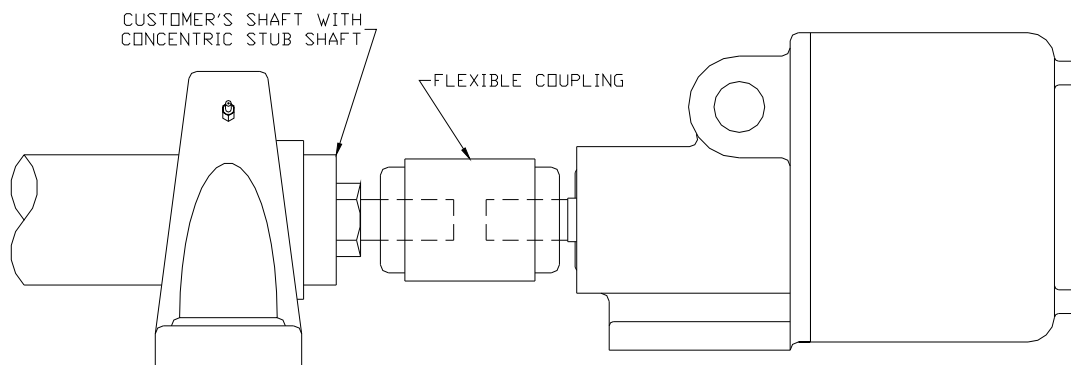
**Figure 4: Control Unit Dimensions**



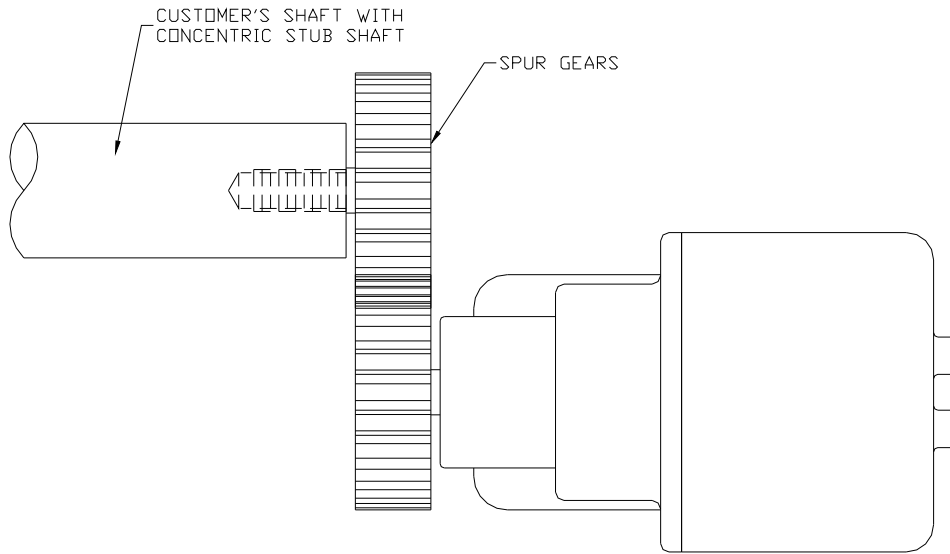
**Figure 5: Sensor dimensions**



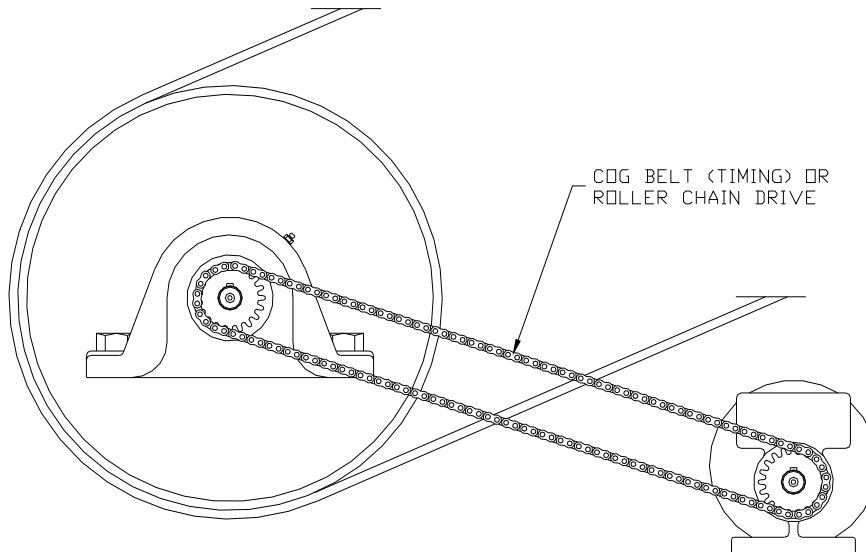
**Figure 6: Use of flexible coupling**



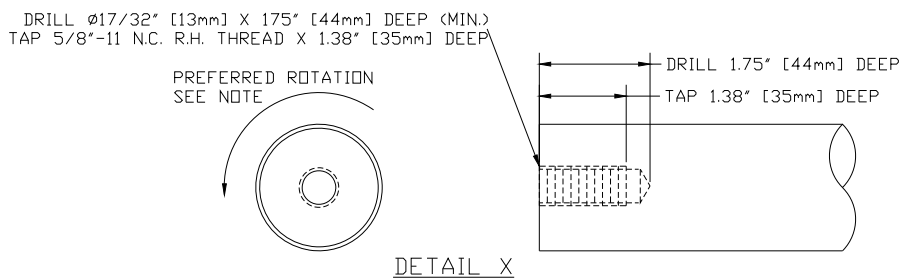
**Figure 7: Offset mount using spur gears**



**Figure 8: Offset mounting using belt / chain drive**

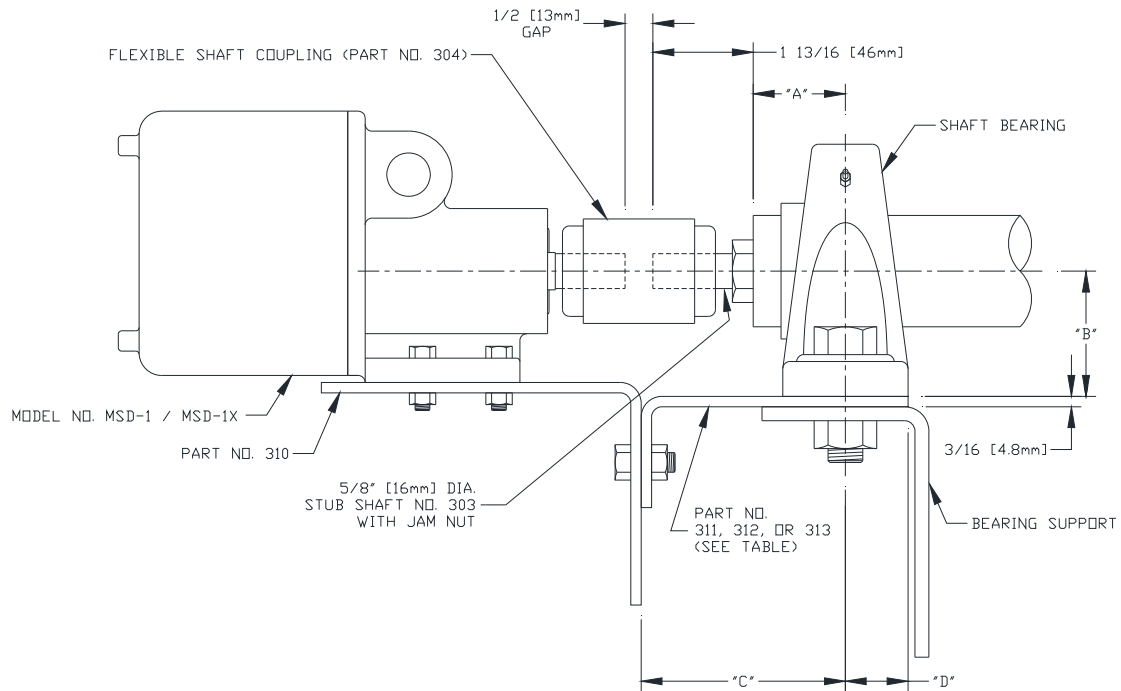


**Figure 9:**

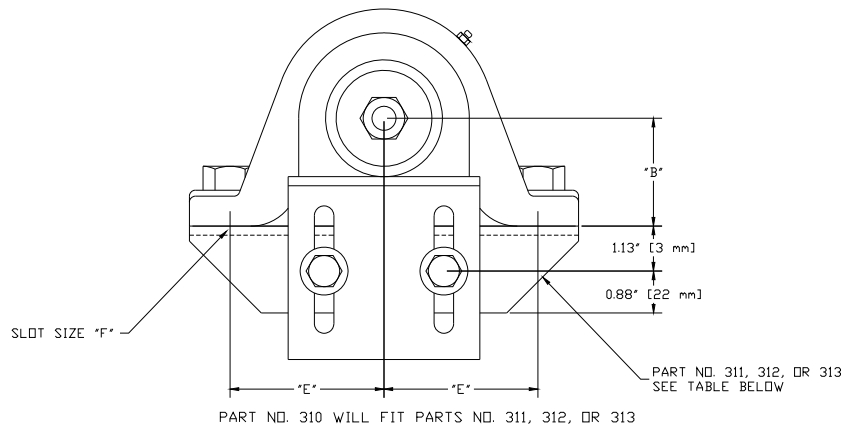


NOTE: WHEN THREADED STUB SHAFT (PART NO. 303) IS USED, IT IS RECOMMENDED THAT THE LOCATION OF THE STUB BE IN THE END OF THE SHAFT THAT ROTATES COUNTER-CLOCKWISE. THIS ALLOWS THE THREADS TO CONTINUE BEING UNDER A CONSTANT FASTENING TORQUE WHILE THE SHAFT TURNS. IF THE ROTATION IS CLOCKWISE OR THE SHAFT IS FOR REVERSING TYPE SERVICE, MAKE SURE THE JAM NUT IS LOCKED TIGHT AGAINST THE SHAFT.

**Figure 10: Typical mounting**



**Figure 11: Bracket chart**



PART NO. 310 WILL FIT PARTS NO. 311, 312, OR 313

| ALL DIMS IN INCHES, EXCEPT DIMS IN [ ] ARE IN MILLIMETERS. |                            |                             |               |              |               |                                    | BEARING BRACKET & SHIM PLATE PART NO. |
|--|----------------------------|-----------------------------|---------------|--------------|---------------|------------------------------------|---------------------------------------|
| SHAFT DIA.   | "A"                        | "B"                         | "C"           | "D"          | "E"           | "F"                                |                                       |
| 1.44<br>[111]  | 1.25 TO 2.00<br>[32 TO 51] | 1.88 TO 2.13<br>[48 TO 54]  | 3.13<br>[79]  | 1.13<br>[29] | 5.38<br>[137] | 0.56 W x 1.31 LG<br>[14 W x 33 LG] | 311                                   |
| 1.94 TO 2.44<br>[49 TO 62]                                 | 1.50 TO 2.56<br>[38 TO 65] | 2.25 TO 3.00<br>[57 TO 76]  | 3.75<br>[95]  | 1.63<br>[41] | 7.38<br>[187] | 0.81 W x 1.94 LG<br>[21 W x 49 LG] | 312                                   |
| 2.94 TO 3.94<br>[75 TO 100]                                | 3.00 TO 3.75<br>[76 TO 95] | 3.13 TO 4.13<br>[79 TO 105] | 4.50<br>[114] | 2.19<br>[56] | 9.63<br>[244] | 1.06 W x 2.56 LG<br>[27 W x 65 LG] | 313                                   |